



Sine Plates



According to the principles of SINE, angle grinding can be done well. High precision of parallelism within 0.002mm and squareness within 0.005 mm. Setup and dressing time reduced to a bare minimum due to simplicity.(ANGLE 0° - 46°)

- Made of quality steel, hardened to HRC 55° - 56°
- Two hardened and ground side rails and one.
- Locking strap included.

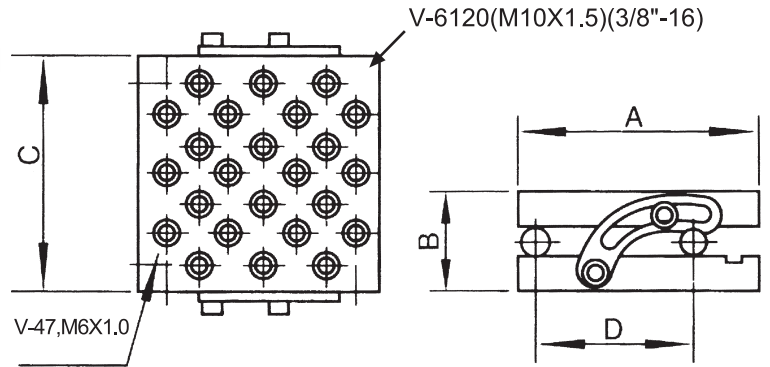

ORDER NO. V-47, V-66, V-6120

| ORDER NO. | A | B | C | D | N.W | CODE NO. |
|-----------|-----|----|-----|-----|-------|----------|
| V-47 | 100 | 62 | 175 | 75 | 6.5kg | 2015-001 |
| V-66 | 150 | 62 | 150 | 100 | 8kg | 2015-002 |
| V-6120 | 150 | 62 | 300 | 200 | 16kg | 2015-003 |



Compound Sine Plate

Made of quality steel, hardened to HRC 55°-62°, 0°, 60° capacity.
 Minute angle step 0.2 built into the front gauge block roll eliminates steps in base plate.
 Two end rails and one locking strap included
 Tapped holes in top.
 Center distance of tools with 0.005mm(0.0001")V-612S within 0.008mm(0.0003")

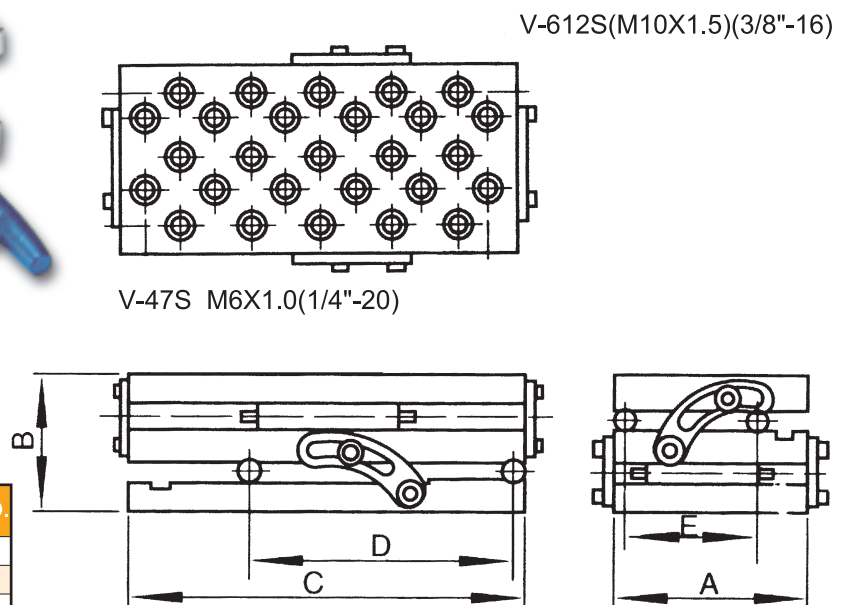

ORDER NO. V-47S, V-66S, V-612S

| ORDER NO. | A | B | C | D | E | N.W | CODE NO. |
|-----------|-----|-----|-----|-----|-----|--------|----------|
| V-47S | 100 | 100 | 175 | 125 | 75 | 9.5kg | 2015-010 |
| V-66S | 150 | 100 | 150 | 100 | 100 | 12.5kg | 2015-011 |
| V-612S | 150 | 100 | 300 | 100 | 100 | 23.5kg | 2015-012 |