

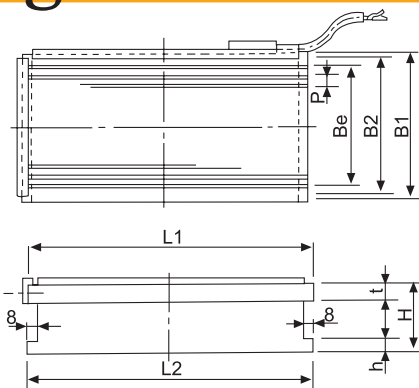

Universal Electro magnetic Chuck

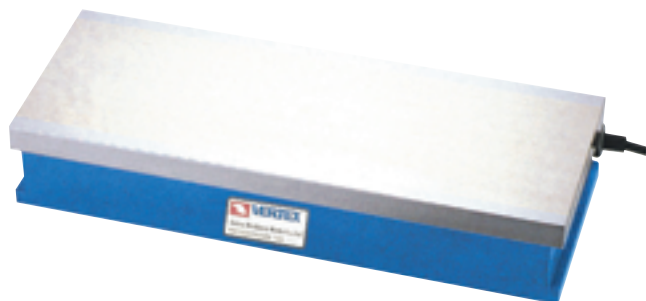

APPLICATION

Polar patterns are pitched in lengthwise direction on this chuck, and is designed for grinding and even light cutting of various types of work pieces, regardless of its thickness.

It is most suitable for grinding, light cutting, buffing and belt-long and thin work pieces in a large lot, usually found difficult when using standard type electromagnetic chucks. (But this is not suitable for small pieces.)

Unit:mm

| ORDER NO. | DIMENSION | CHUCKING SIZE | | | | POLE PITCH | CHUCK MOUNTING FACE | | | | VOLTAGE | CURRENT | WEIGHT KG | CODE NO. |
|-----------|-----------|---------------|-----|----|-----|------------|---------------------|-----|----|----|---------|---------|--------------|----------|
| | | B1 | L1 | t | Be | P | B2 | L2 | h | H | | | | |
| VEM-1530L | 150 X300 | 150 | 300 | 20 | 125 | 4(1+3) | 148 | 300 | 20 | 70 | DC115V | 0.39A | 19kg | 2015-241 |
| VEM-1535L | 150X350 | 150 | 350 | 20 | 125 | 4(1+3) | 148 | 350 | 20 | 70 | DC115V | 0.52A | 23kg | 2015-242 |
| VEM-1545L | 150X450 | 150 | 450 | 20 | 125 | 4(1+3) | 148 | 450 | 20 | 70 | DC115V | 0.60A | 29kg | 2015-243 |
| VEM-2040L | 200X400 | 200 | 400 | 20 | 173 | 4(1+3) | 198 | 400 | 20 | 70 | DC115V | 0.69A | 34kg | 2015-244 |
| VEM-2045L | 200X450 | 200 | 450 | 20 | 173 | 4(1+3) | 198 | 450 | 20 | 70 | DC115V | 0.90A | 38kg | 2015-245 |
| VEM-2050L | 200X500 | 200 | 500 | 20 | 173 | 4(1+3) | 198 | 500 | 20 | 70 | DC115V | 1.10A | 42kg | 2015-246 |
| VEM-2060L | 200X600 | 200 | 600 | 20 | 173 | 4(1+3) | 198 | 600 | 20 | 70 | DC115V | 1.31A | 51kg | 2015-247 |
| VEM-2550L | 250X500 | 250 | 500 | 20 | 225 | 4(1+3) | 248 | 500 | 20 | 70 | DC115V | 1.33A | 62kg | 2015-248 |
| VEM-3060L | 300X600 | 300 | 600 | 20 | 273 | 4(1+3) | 298 | 600 | 20 | 70 | DC115V | 1.52A | 98kg | 2015-249 |
| VEM-4060L | 400X600 | 400 | 600 | 25 | 373 | 4(1+3) | 398 | 600 | 20 | 80 | DC115V | 1.81A | 135kg | 2015-250 |



Super-Powerful Electric magnetic chuck

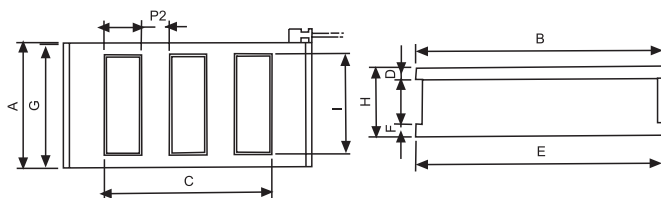

APPLICATION

Most efficient for heavy cutting with milling machine, shaper, planer and planomiller. It displays the power for the thick work and the high speed cutting operation.

Unit:mm

| ORDER NO. | DIMENSION | CHUCKING SIZE | | | | | POLE PITCH | | CHUCK MOUNTING FACE | | | | VOLTAGE | CURRENT | WEIGHT N.W. | CODE NO. |
|------------|-----------|---------------|------|-----|----|-----|------------|----|---------------------|------|----|-----|---------|---------|----------------|----------|
| | | A | B | C | D | I | P1 | P2 | G | E | F | H | | | | |
| VEM-2040Z | 200X400 | 200 | 400 | 332 | 20 | 160 | 40 | 35 | 194 | 400 | 20 | 110 | DC-90V | 0.71 | 54kg | 2015-251 |
| VEM-2050Z | 200X500 | 200 | 500 | 422 | 20 | 160 | 48 | 34 | 194 | 500 | 20 | 110 | DC-90V | 0.91 | 75kg | 2015-252 |
| VEM-2060Z | 200X600 | 200 | 600 | 520 | 20 | 160 | 48 | 30 | 194 | 600 | 20 | 110 | DC-90V | 1.00 | 80kg | 2015-253 |
| VEM-2550Z | 250X500 | 250 | 500 | 422 | 20 | 200 | 42 | 34 | 240 | 500 | 20 | 120 | DC-90V | 1.16 | 90kg | 2015-254 |
| VEM-3060Z | 300X600 | 300 | 600 | 520 | 20 | 240 | 48 | 30 | 290 | 600 | 20 | 120 | DC-90V | 1.63 | 130kg | 2015-255 |
| VEM-4080Z | 400X800 | 400 | 800 | 718 | 25 | 340 | 48 | 30 | 390 | 800 | 20 | 120 | DC-90V | 2.53 | 230kg | 2015-256 |
| VEM-40100Z | 400X1000 | 400 | 1000 | 917 | 25 | 340 | 45 | 35 | 390 | 1000 | 20 | 120 | DC-90V | 2.96 | 288kg | 2015-257 |
| VEM-50100Z | 500X1000 | 500 | 1000 | 917 | 25 | 430 | 45 | 35 | 490 | 1000 | 20 | 120 | DC-90V | 3.96 | 360kg | 2015-258 |
| VEM-60100Z | 600X1000 | 600 | 1000 | 917 | 25 | 530 | 45 | 35 | 590 | 1000 | 20 | 120 | DC-90V | 5.30 | 432kg | 2015-259 |