

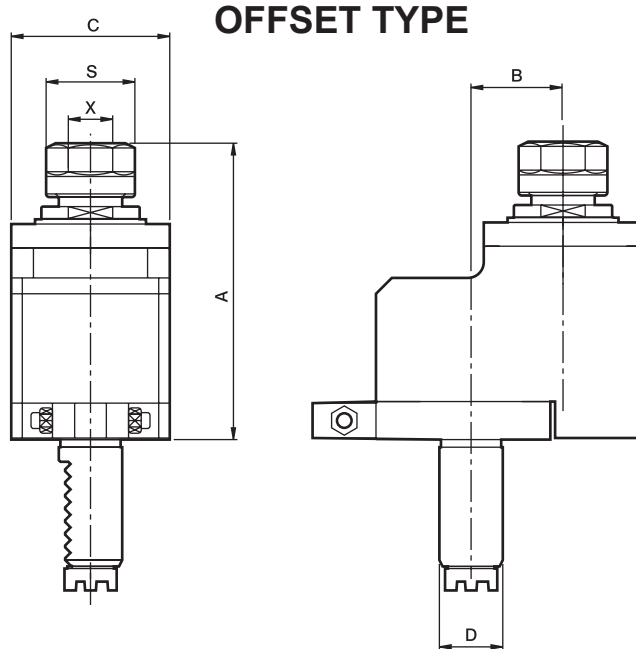

Axial Drilling And Milling Heads

TYPE SPUR COUPLING-MT



OFFSET TYPE

OFFSET

- Collet is not included.
- External coolant supply
- To be used for collet DIN 6499

DIMENSIONS

Order No.	D DIN 69880	X Capacity	S	Maximum R.P.M.	i	A	B	C	CODE NO.
DA20MT1629	20	1-10 ER16	32	4000	1:1	93.5	29	50	5006-133□
DA30MT2529	30	1-16 ER25	42	4000	1:1	100	29	60	5006-134□
DA30MT2529/1	※ 30	2-20 ER32	42	8000	1:2	100	29	60	5006-135□
DA40MT3250	40	2-20 ER32	50	4000	1:1	113	50	80	5006-136□
DA50MT4065	50	3-26 ER40	63	3000	1:1	124	65	86	5006-137



Radial Milling Heads

TYPE SPUR COUPLING-MT

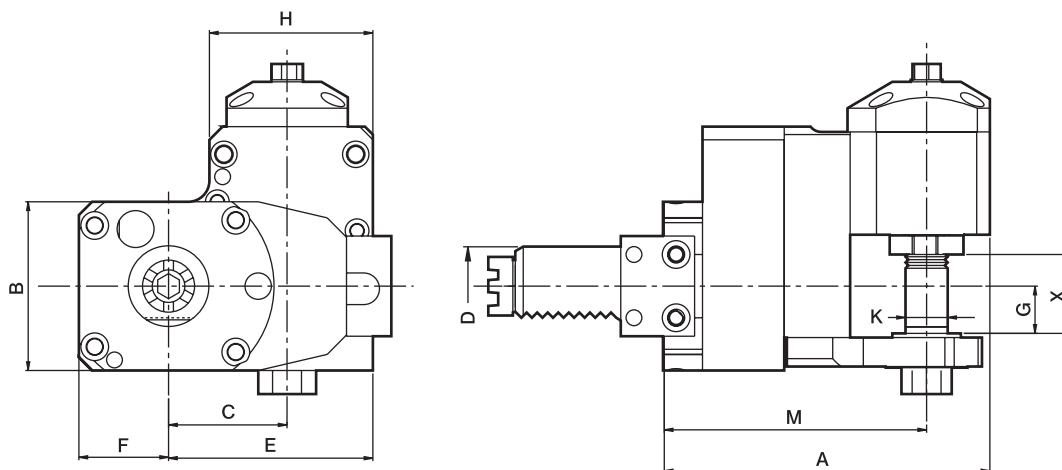

- External coolant supply

DIMENSIONS

Order No.	D DIN 69880	X Capacity	Maximum R.P.M.	i	A	B	C	E	F	G	H	K	M	CODE NO.
BR30MT16C/3 BL30MT16C/3	30	16.6	3000	3:1	124	64	45	77.5	34	18	62	16	100	5006-138